

Combustion Safety

NFPA 86

J.J. Lukacs

Copyright © by The North American Manufacturing Company All Rights Reserved

The following information shown in this presentation, printed handouts, or any part thereof, may not be copied, reproduced, or distributed in any form without the expressed written consent of North American. The North American Manufacturing Company assumes no responsibility for any errors or omissions; nor is any liability assumed for damages resulting from the use or misuse of any of the data contained in this presentation.

Further, The North American Manufacturing Company reserves the right to make changes to the data at any time without notice.

StepFire and TwinBed II are trademarks of The North American Manufacturing Company

This series of updated articles is intended to summarize key points of NFPA 86 Standard for Ovens and Furnaces, 2007 edition, limited to the requirements for combustion systems. This article should not be viewed as a comprehensive summary of all NFPA requirements for kiln applications. It is our opinion that ceramic kilns fall within the scope of NFPA 86 as supported by the enumeration of applications governed by NFPA 86 under Annex A.1.1.2. This Standard applies to “new installations or to alterations or extensions to existing equipment”. The Retroactivity clauses may require compliance for existing equipment. It is our opinion that all operating combustion systems should be evaluated and brought into compliance with the current Standards.

Given the complexity and diversity of kilns, this article is not intended to relieve any user or company from taking it upon themselves to gain a thorough understand of NFPA Codes and Standards and the requirements for compliance of their own operation. As such the authors and The North American Mfg. Co. disclaim liability for any personal injury, property or other damages of any nature whatsoever, whether special, indirect, consequential or compensatory, directly or indirectly resulting from the publication, use of, or reliance on this article.

Sometimes it takes an incident to raise awareness

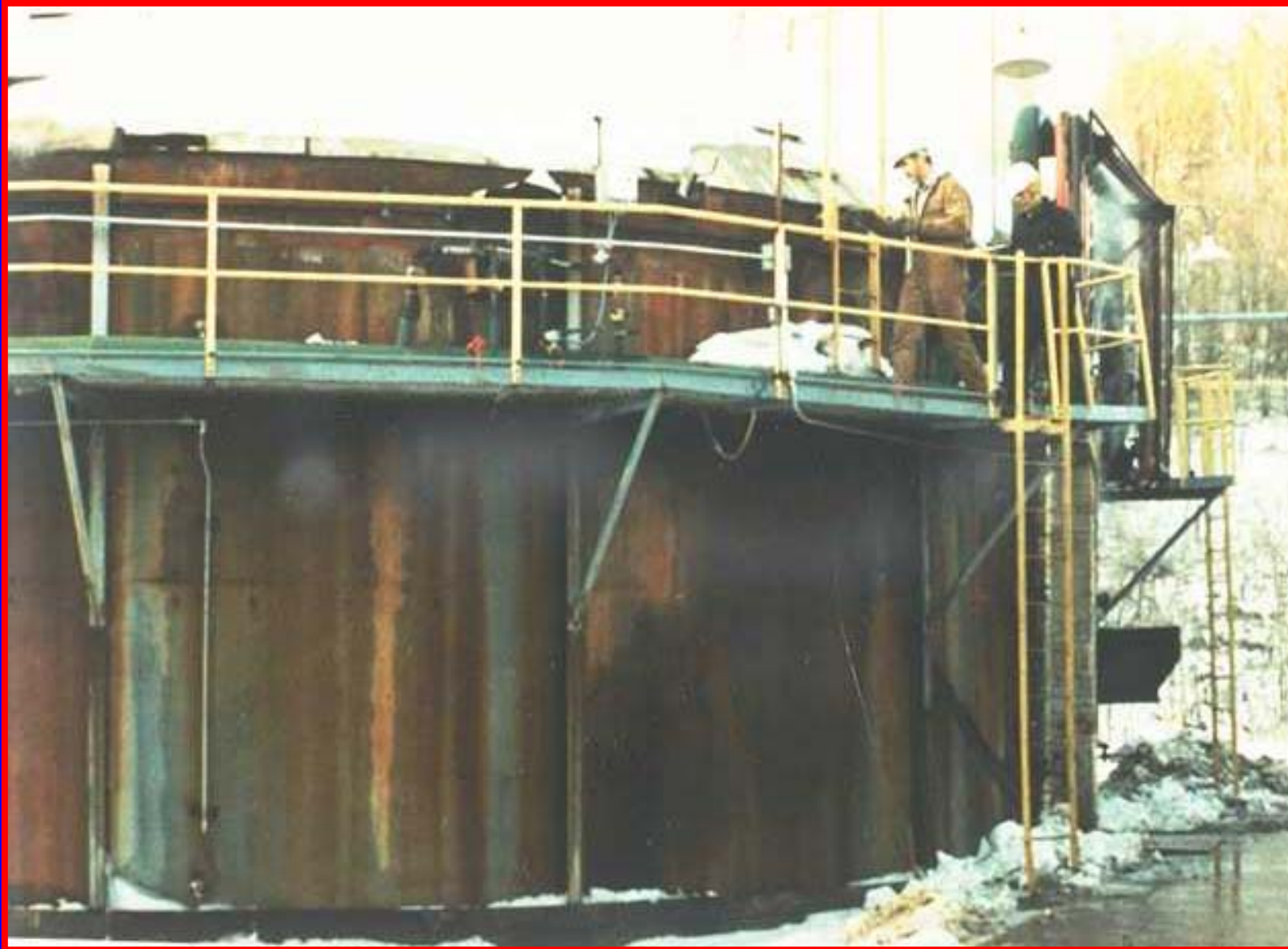

NFPA 86, Standard for Ovens and Furnaces, 2007 Edition is the current version of the standard addressing the safety aspects of the design, construction, and operation of gas and oil-fired furnaces.

Its Purpose states:

“This standard provides the requirements for furnaces to minimize the fire and explosion hazards that can endanger the furnace, the building, or personnel.”

Authority Having Jurisdiction (AHJ)

“An organization, office, or individual responsible for enforcing the requirements of a code or standard, or for approving materials, and installation, or a procedure.”

The AHJ for your particular location could be your insurer or the local fire marshal, for instance. Whoever it is, the AHJ should be the point of definitive reference for all compliance matters.

Sometimes it takes an incident to raise awareness



The Elements of Combustion

When you have the right fuel and air for useful combustion, you have the right fuel and air for explosive combustion.

The Elements of Explosive Combustion

- Air (just the O₂)
- Fuel
- Proportioned
- Mixing
- Source of Ignition
- Accumulation
- Confinement

The Elements of Combustion

- Air (just the O₂)
- Fuel
- Proportioned
- Mixing
- Source of Ignition

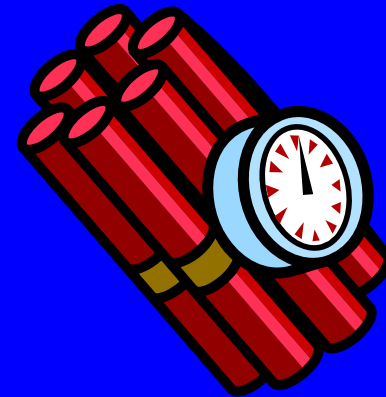

Safety Valves

Listed

UL, FM, CSA, CGA, CE



for the intended service

Safety Shutoff Valve (SSV)

Manual or Auto Reset

Proof of closure

Indication of closure

Fuel

Natural gas, Propane etc.

Oil

Pressure

Closing & Opening

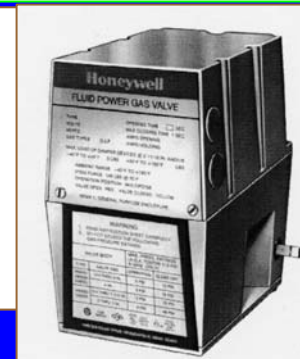
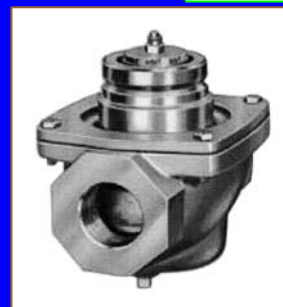

SSV Systems

Fuel Safety Trains

**Required gas train for most
one burner systems.**



'2 valves in
1 body'

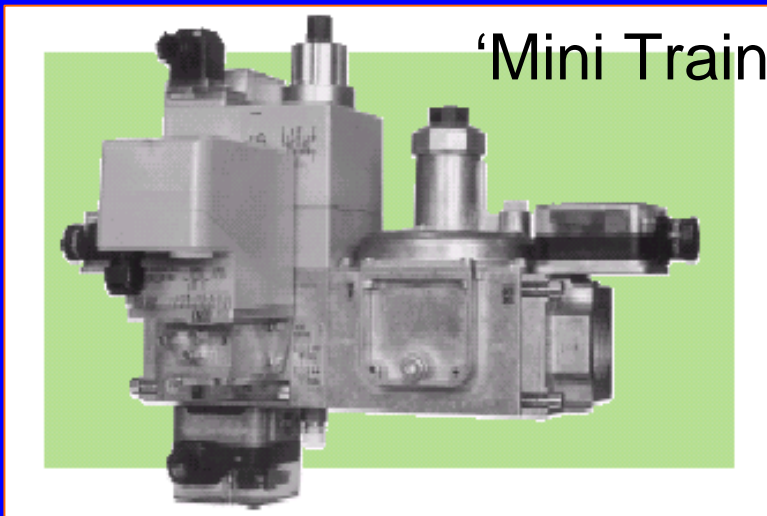
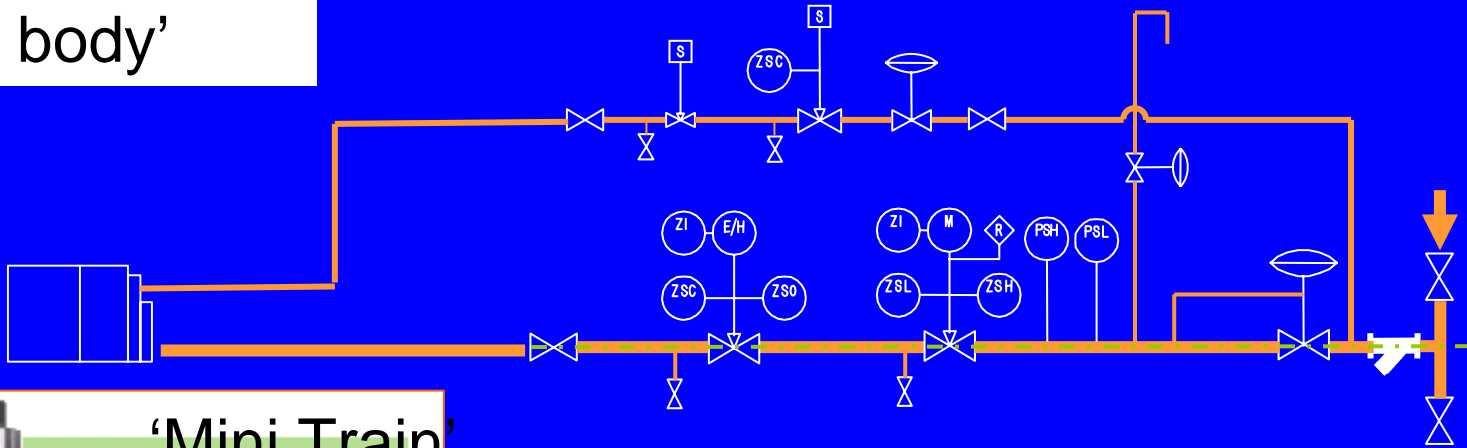

'Mini Train'

Sometimes it takes an incident to raise awareness



SSV Systems

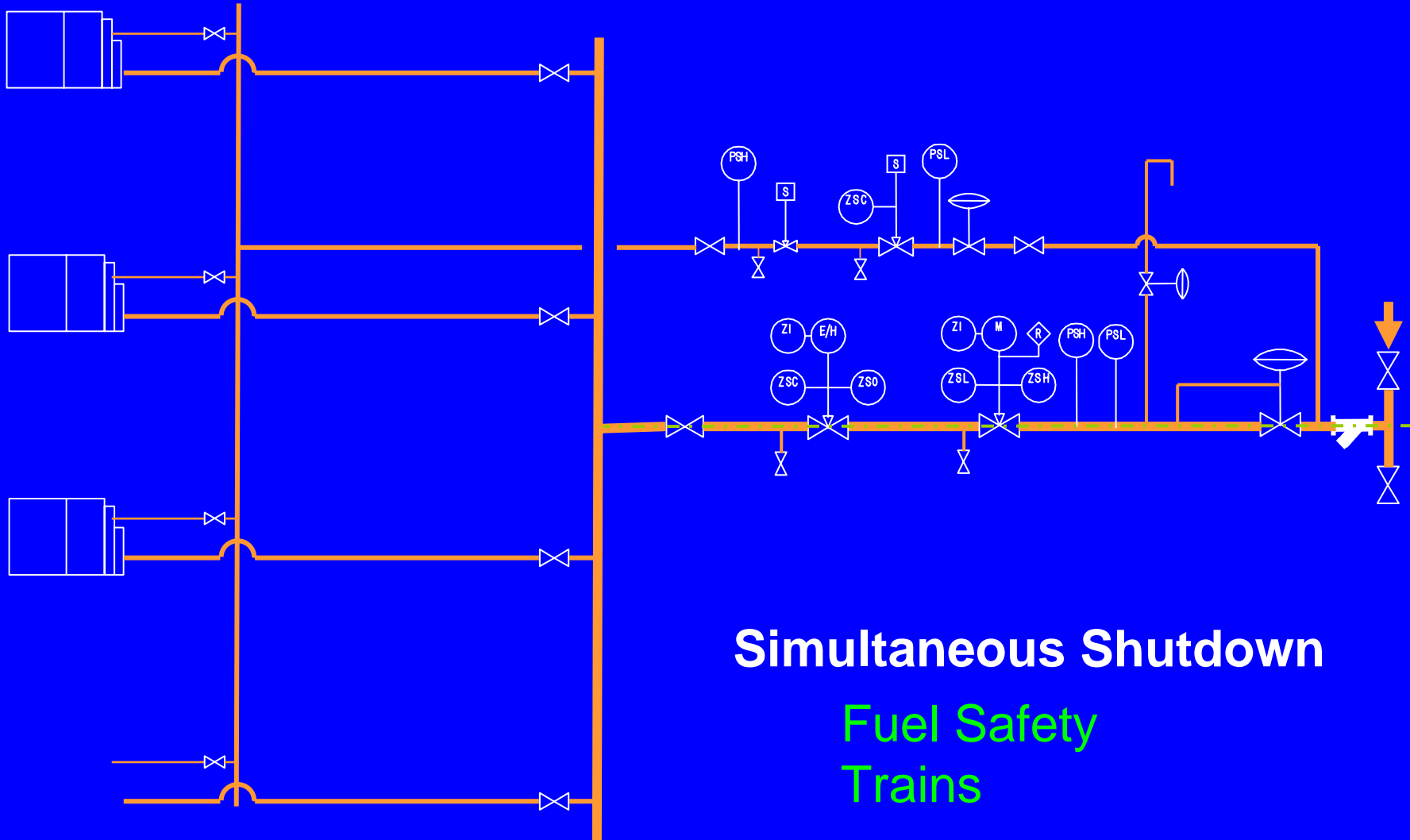

Simultaneous Shutdown

**Fuel Safety
Trains**

SSV Systems

Required gas train for most multi-burner systems where a single burner shuts down on it's flame failing.

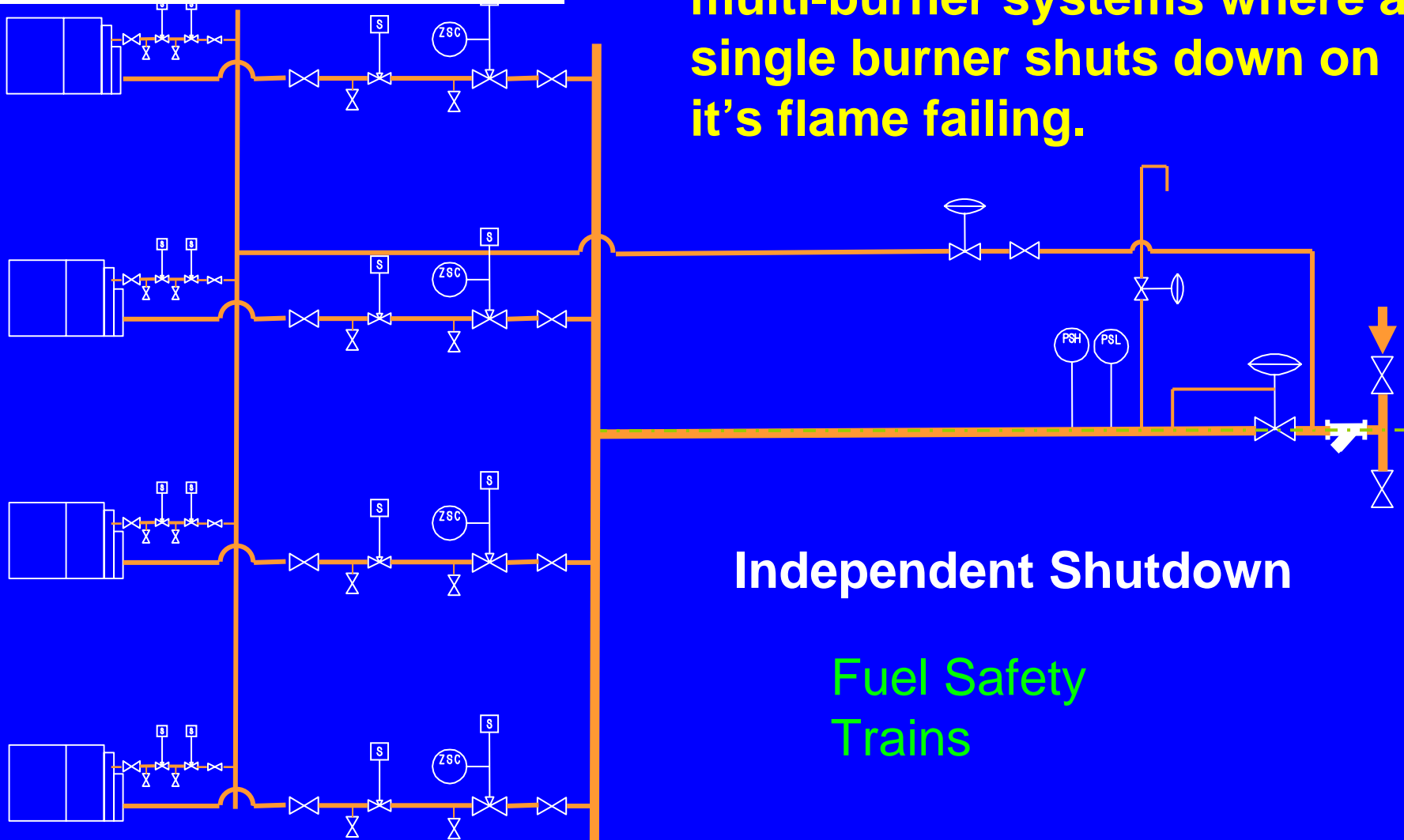

Independent Shutdown

Fuel Safety
Trains

SSV Systems

Fuel Safety Trains



One valve exceptions

8.7.2
exceptions

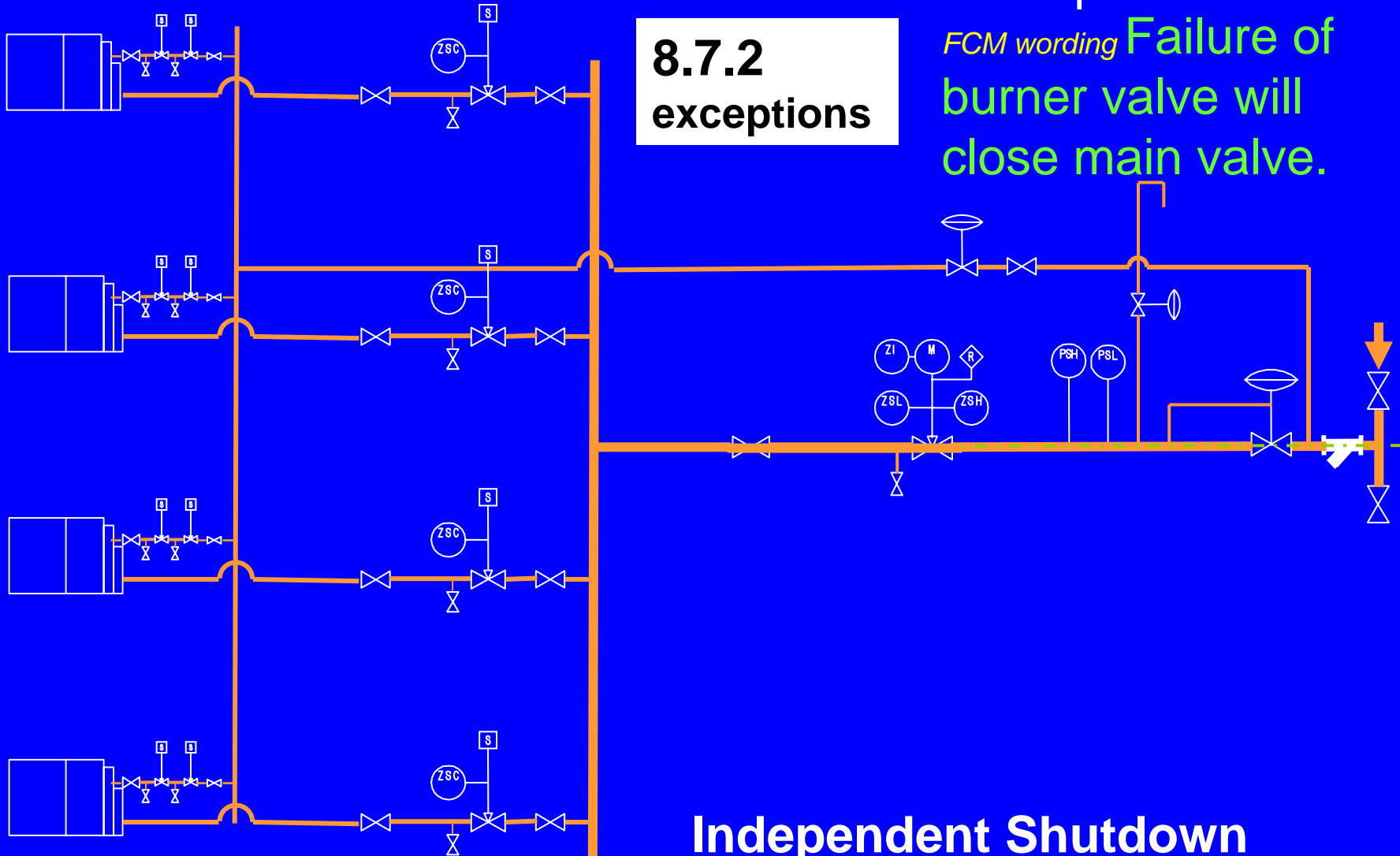
FCM wording Failure of burner valve will close main valve.



Independent Shutdown

| Key | Safety shutoff valve requirements | | |
|--|---|---|---|
| Safety shutoff valve | Under 150,000 Btu/hr | 150,000 to 400,000 Btu/hr | Over 400,000 Btu/hr |
| Safety shutoff valve with visual identification |  |  |  |
| Safety shutoff valve with visual identification and proof of closure | | | |

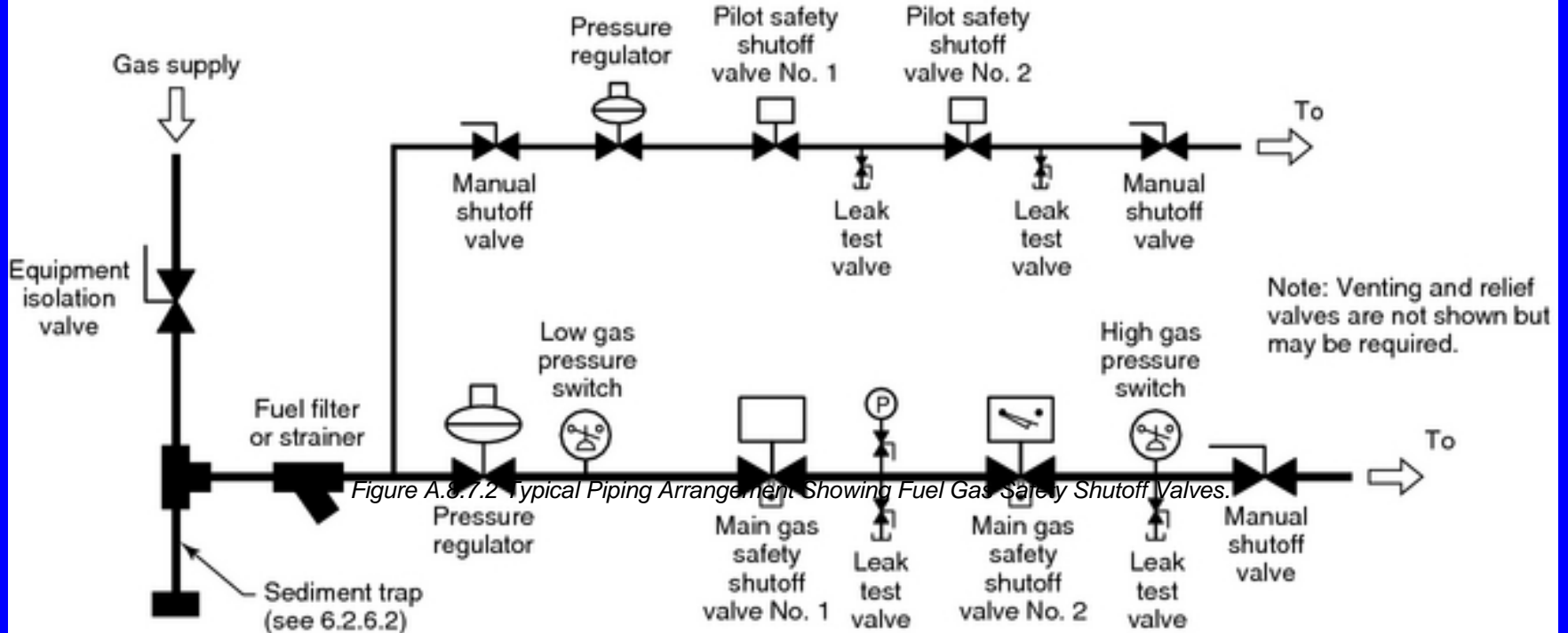

Figure A.8.7.2 Typical Piping Arrangement Showing Fuel Gas Safety Shutoff Valves.

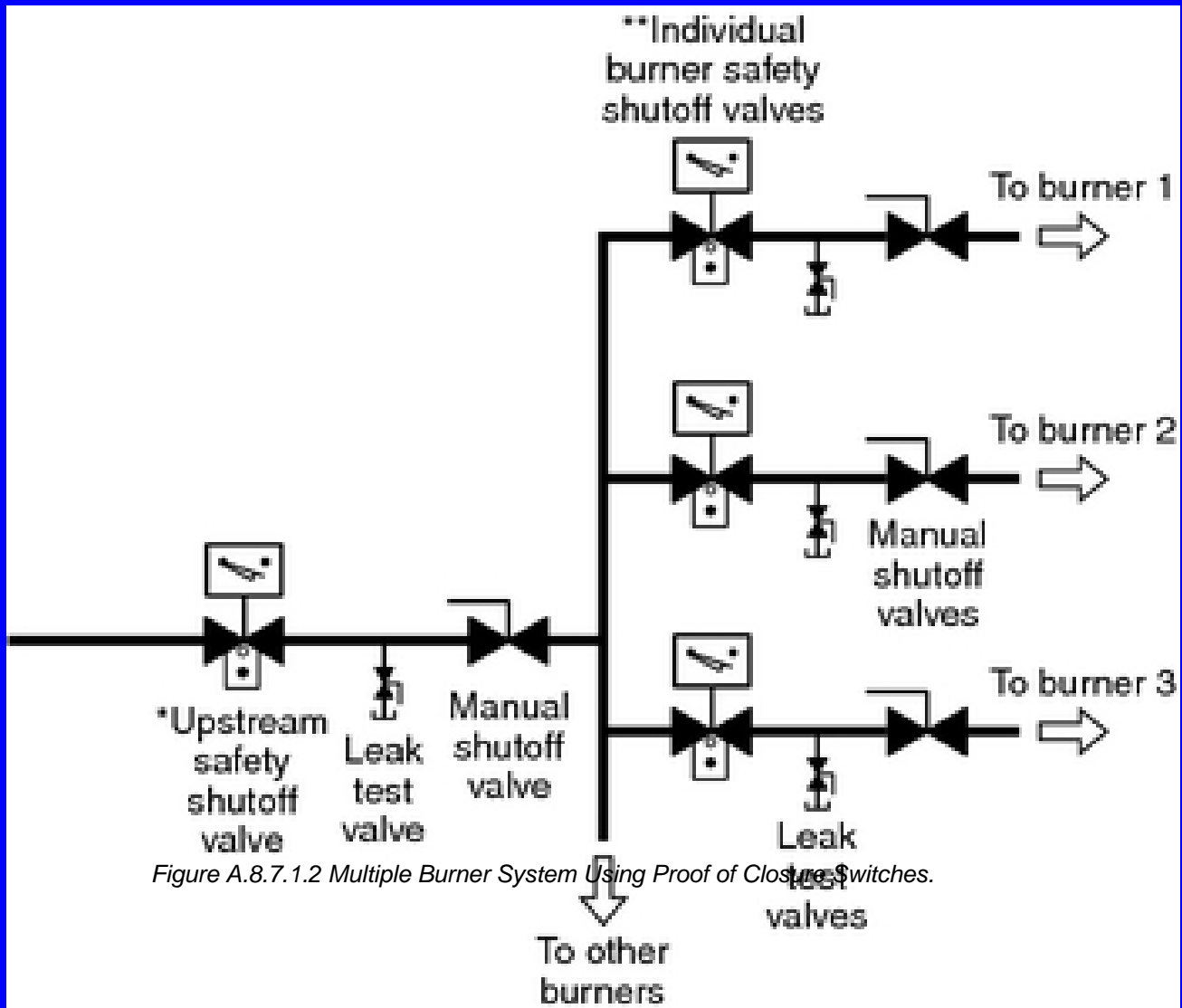

Figure A.8.7.1.2 Multiple Burner System Using Proof of Closure Switches.

* Interlocked with preignition prepurge

** Interlocked with upstream safety shutoff valve

'The Midnight Tweaker'

NEVER JUMPER, BY-PASS OR FORCE ANY SAFETY LIMIT

The Safety Switch Bypass Artist.

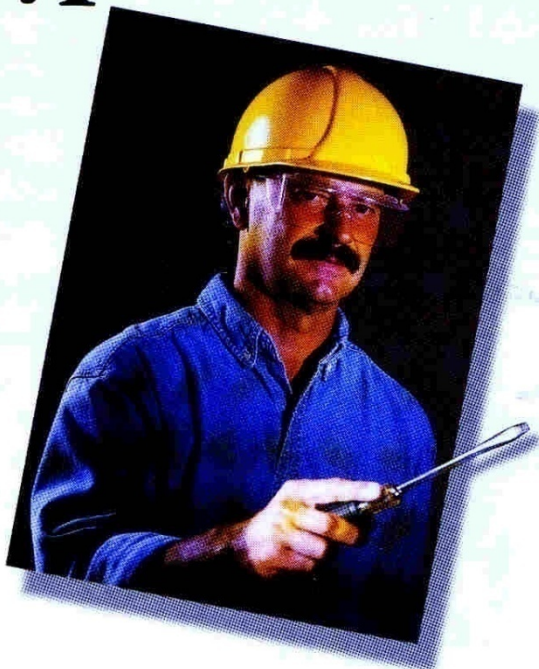

Stop him before he stops you.

Industrial Safety Hall of Shame

Dishonorable Mention

6.2.3* Comb

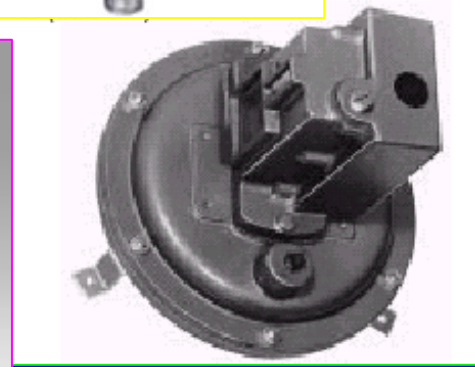
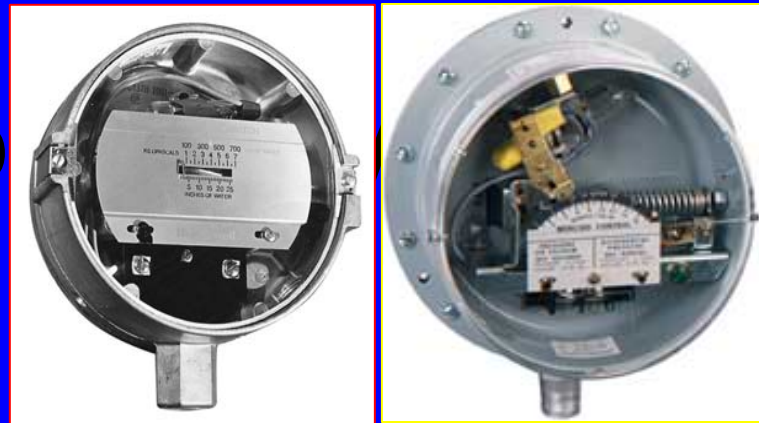

Listed
UL, FM, CSA, *ect.
for the intended service
Media (gas, air, oil,) &
Pressure
Manual or Auto Reset

- 6.2.3.4* Where primary or secondary combustion air is provided mechanically, combustion airflow or pressure shall be proven and interlocked with the safety shutoff valves so that **fuel gas cannot be admitted prior to establishment of combustion air and so that the gas is shut off in the event of combustion air failure.**

6.2.3* Combustion Air.

6.2.3.4* (airflow or pressure shall be proven)

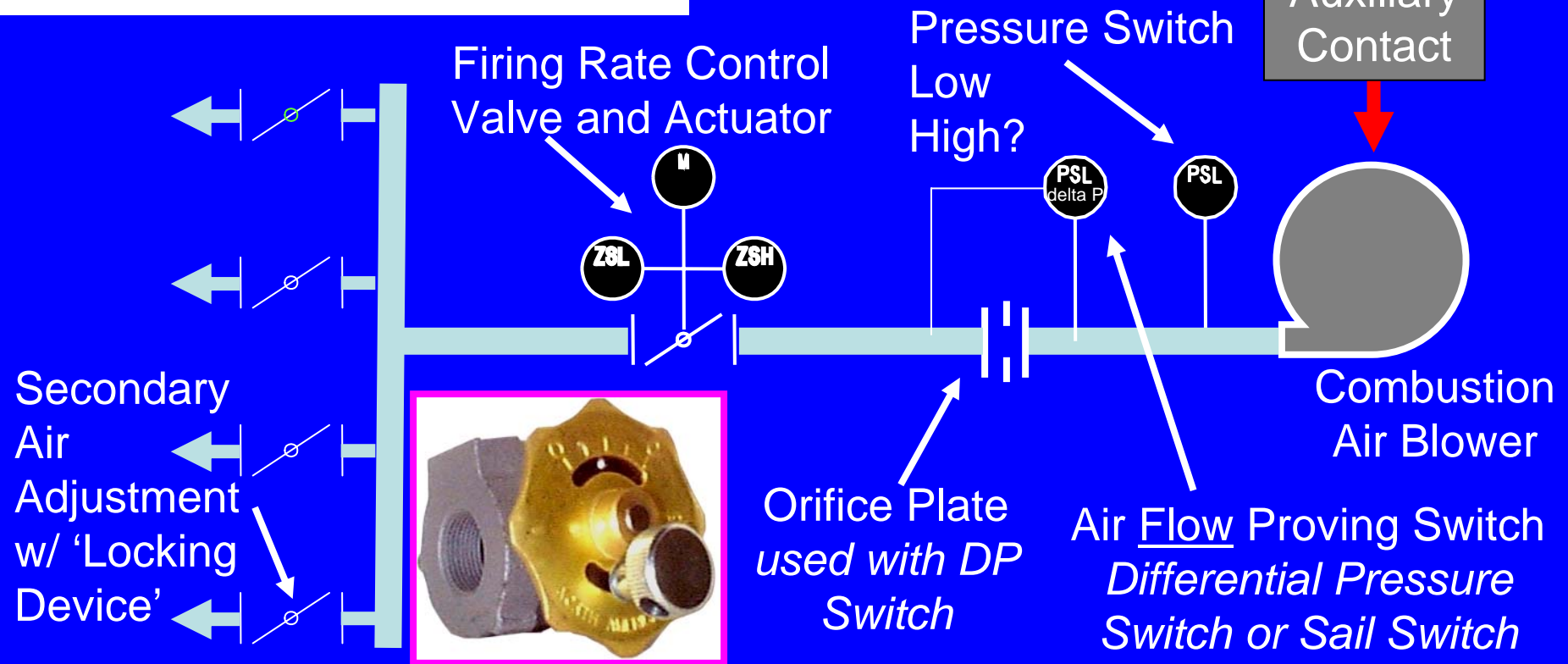

- 6.2.3.6 Where a secondary air adjustment is provided, adjustment shall include a **locking device to prevent an unintentional change in setting.**

Sail Switch Pitot Tube

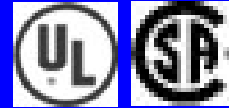

- Listed
 - UL, FM, CSA, CE
- for the intended service
 - Media & Pressure

Flow (Proving) Switches

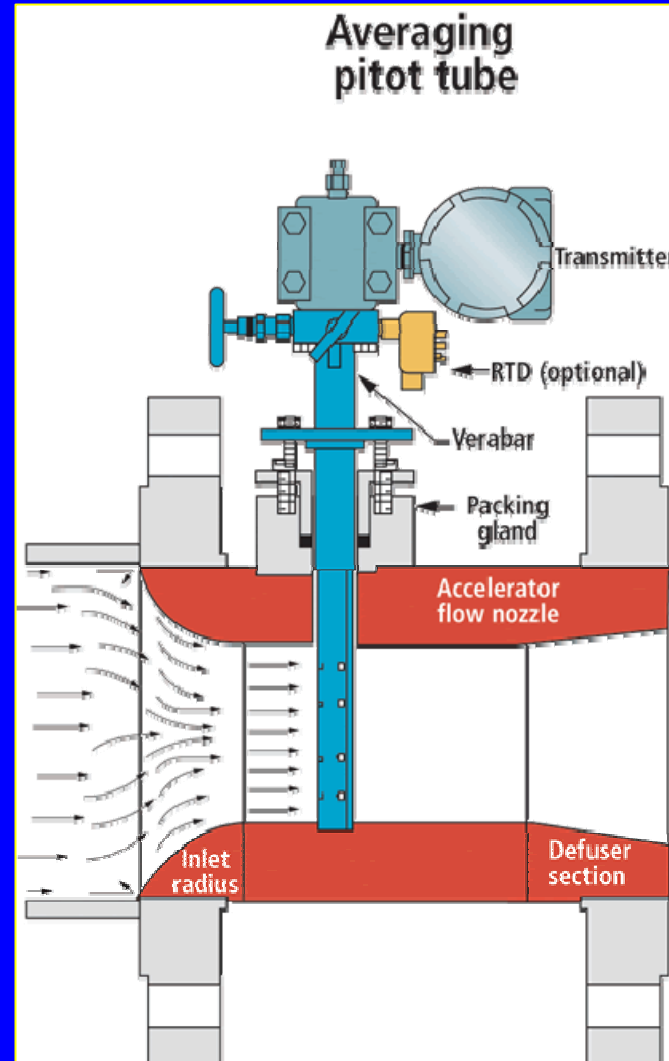
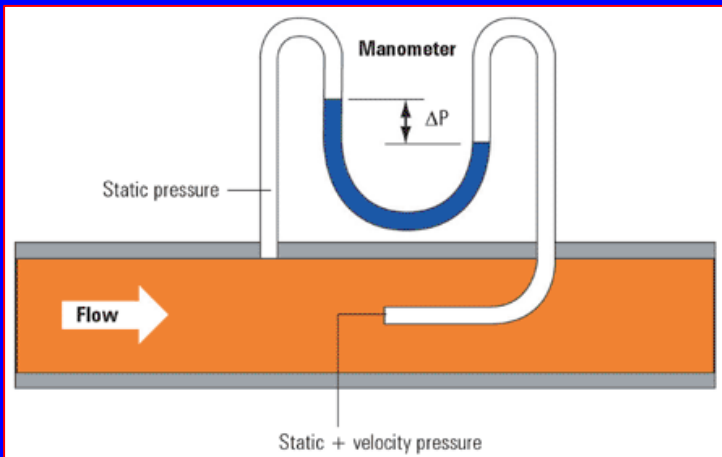

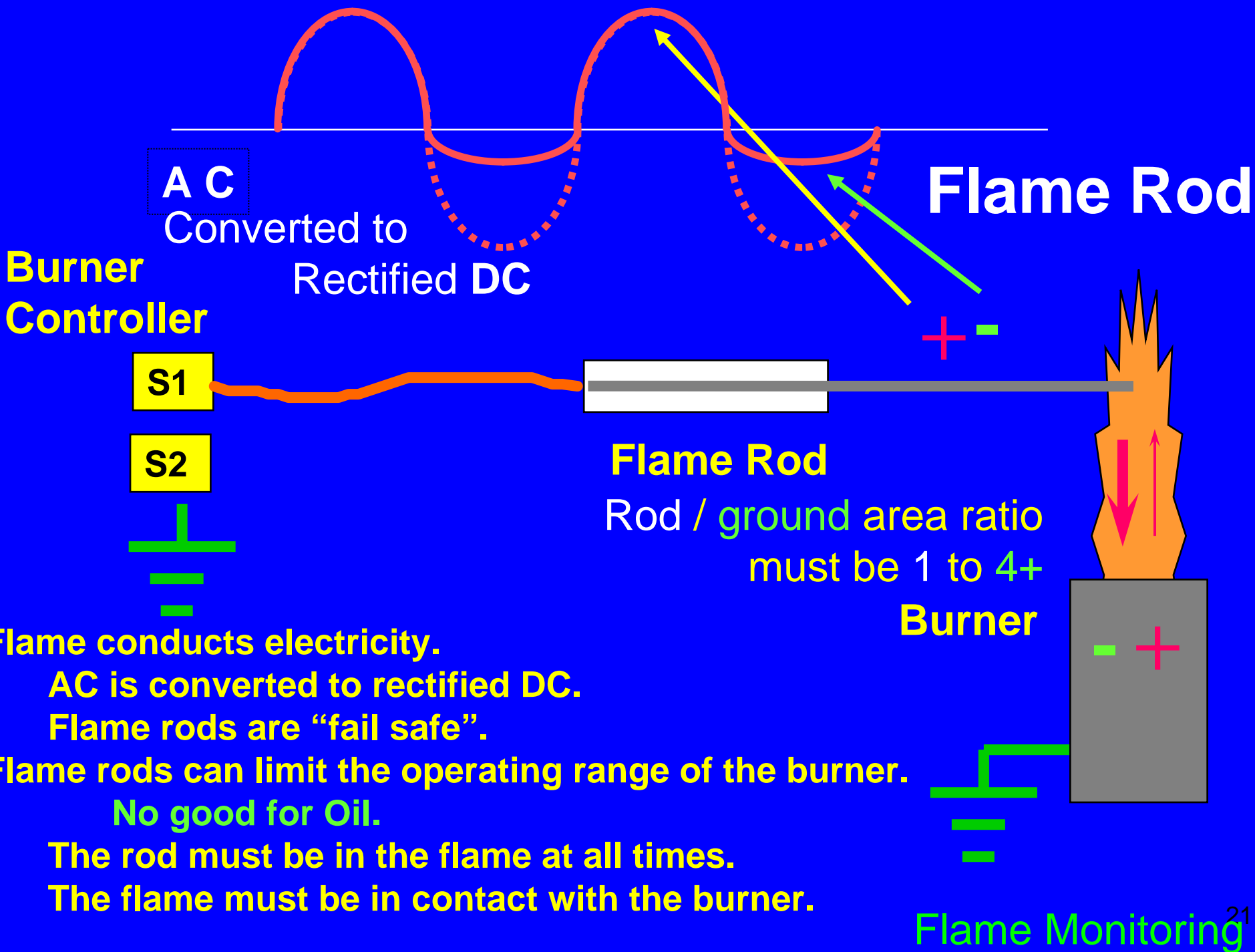

Flame Monitoring

Flames give off Ultraviolet rays.
Most burner safety system are based on UV detection.

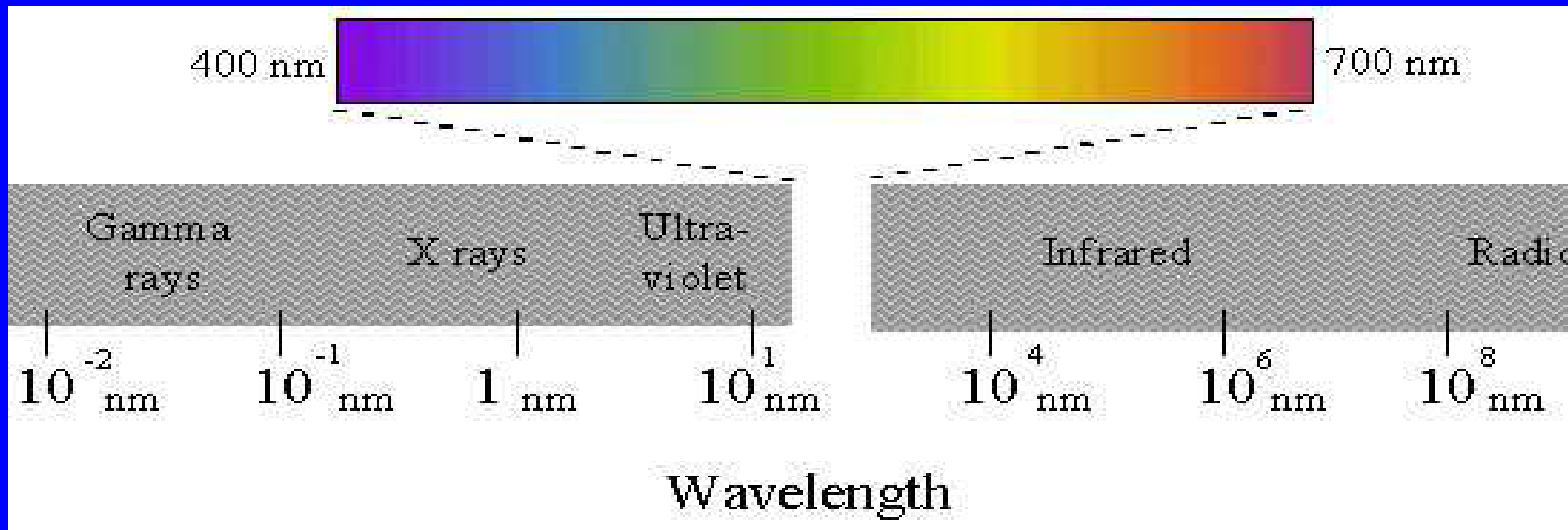

- UV detector tubes can fail “on”.
 - Detectors can be made “safe”.

Ultraviolet (UV)

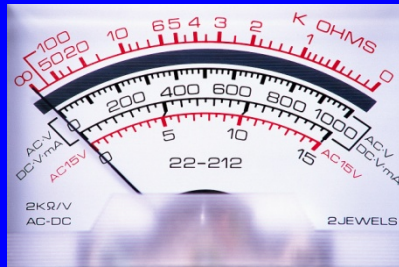

cathode

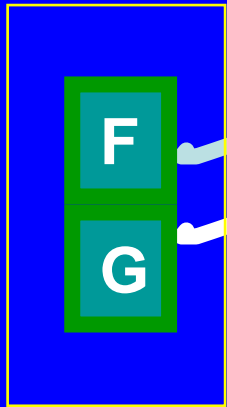

anode

gas filled tube

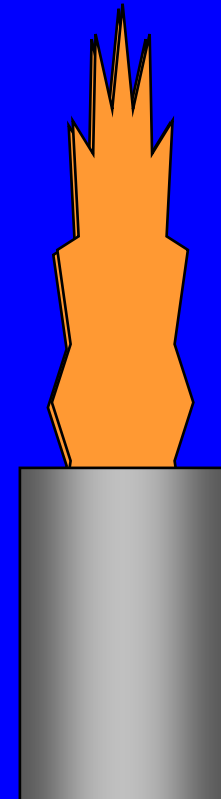
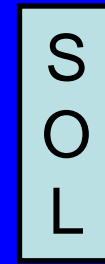
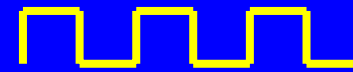

Ultraviolet Is found in...

Flame, Sun, Welding Arc, Mercury vapor lights, Spark (from the igniter), Other Burners **UV is reflective.**

Kiln Shutdown Cautions:

It is important to follow the correct shutdown procedures whenever the kiln is shut down, even for short durations. Following any shutdown, it must be quickly determined that the fuel to the kiln is stopped simultaneously with the shutdown. The main manual fuel isolation valve(s) is required to be closed immediately following the shutdown. NFPA 86 requires that the operation and leak tightness of the main SSOV's be tested and documented at the prescribed intervals (and at least annually). We recommend that the SSOV's be replaced at proper intervals.

Whenever there is a possibility that there is an indeterminate (and possibly combustible) gas mixture in the kiln, the kiln must be allowed to cool to a temperature that will permit a purge compliant with NFPA 86.

There may be other critical shutdown procedures to be followed, so please refer to and follow the kiln manufacturer's shutdown procedures.

Types of Startup

- Cold Start
- Hot Start [Relight]

Cold Start

- **Pre-start**
- **Purge**
- **Start up supervised burners**

How to start a kiln with limited flame supervision

- If flame supervision is in preheat section
- If flame supervision is in high heat section
- If flame supervision is in all zones

Hot Restart

1400F Bypass Controller:

A properly applied 1400F Bypass Controller can be used to activate unsupervised burners. (Ref: 8.9.1(3))

A properly applied 1400F Bypass Controller can be used to avoid a re-purge. (Ref: 8.4.1.8(1)) It is our opinion that all fired zones must be suitably proven to be above 1400F in order to apply 8.4.1.8(1).

**Why do Women Live
Longer Than Men?**

Safety Questions ???



Given the complexity and diversity of combustion applications, this presentation is not intended to relieve any user or company from taking it upon themselves to gain a thorough understanding of NFPA and other applicable codes and standards and the requirements for compliance for their own operation. As such, the author and North American Mfg. Co., disclaim liability for any personal injury, property or other damages of any nature whatsoever, whether special, indirect, consequential or compensatory, directly or indirectly resulting from the publication, use of, or reliance on this article.



Did this whet your appetite to learn more?